

KEY DATA

- Solid-machined version (machined from a barstock) or tubular version (made from tubes and welded)
- Connection to the process by flange, screw, weld or clamp-fitting
- Straight, tapered, stepped or even helical design
- Large range of insertion lengths and diameters
- Wake frequency calculation according to ASME PTC 19.3 TW
- Execution according to DIN 43772



Van Stone design



Helical design



Thermowell range

➤ BENEFITS ◀

- Thermowell version and connection type fully adaptable to your application
 - Available in Van Stone design with lap flange
 - Available in helical design to withstand vibration stresses
 - To protect the temperature sensor
 - Allows instrument change with stopping the installation
- Thermowell marked with the casting number for good traceability of the material



The thermowell - machined from solid version is used for severe process conditions (high temperature, pressure or high flow).

The thermowell - tubular version is more suitable for standard applications with no significant constraint.

TUBULAR THERMOWELL

- Materials: stainless steel, carbon steel, monel, hastelloy, duplex, super-duplex, PTFE, PVC...
- Possible coating : PTFE, PA, stellite, tantalum
- Standard shape: straight
- Process connection : flange, screw, weld or clamp-fitting (for high pressure up to 1000 barg)
- Instrument connection : NPT female / male threaded (other on request)
- Customised immersion length, inside and outside diameters according to customer specification
- Maximum acceptable pressure and temperature: according to the thermowell design (size, material, flange rating) and process conditions (flow rate, fluid velocity)



Tubular thermowells with screw and flange fittings with different extension lengths

MACHINED FROM SOLID THERMOWELL

- Materials: stainless steel, carbon steel, monel, hastelloy, duplex, super-duplex, PTFE, PVC...
- Possible coating : PTFE, PA, stellite, tantalum
- Standard shape : straight, tapered or stepped ⁽¹⁾
- Helical design recommended to reduce vibration stresses ⁽²⁾
- Process connection: screw, flange (with sealing weld, with full penetration weld or solid machined flange), weld or clamp-fitting (for high pressure up to 1000 barg)
- Van Stone design with lap flange - advantage: possibility of manufacturing the thermowell and the flanges in different materials, useful when the thermowell is in contact with an aggressive / corrosive fluid and it must be made of a specific material

(1) a change in section or reduction in diameter allows to move to a thinner thickness at the end of the thermowell for better responsiveness

(2) detail on the helical thermowell in the next chapter

- Instrument connection : NPT female / male threaded (other on request)
- Customised immersion length, inside and outside diameters according to customer specification
- Maximum acceptable pressure and temperature: according to the thermowell design (size, material, flange rating) and process conditions (flow rate, fluid velocity)
- Stress calculation according to ASME PTC 19.3 TW standard by Deltafluid engineering office depending on customer requests



Solid machined straight or tapered design thermowell with screw or flange process connection

DETAIL ON THE HELICAL SHAPED THERMOWELL

- To be used if the stress calculation according to ASME PTC 19.3 TW is unfavorable
- The helical-shaped thermowell reduces induced vibrations: helical strakes arranged around the thermowell prevent the formation of vortices. Thanks to the reduced amplitudes of the vortices, vibrations of the thermowell are reduced (lower stresses, acceptable according to the ASME PTC 19.3 TW standard).
- In critical process conditions, in case of vibrations, it is therefore no longer necessary to shorten the thermowell stem and to increase the root and tip diameter or to use a support collar in order to stabilise the thermowell stem.
- The response time remains optimal with the helical version unlike the version with reduced length and increased diameter.
- Available in version with helicoid drilled into the mass or in version with welded helicoid
- Process connection with standard flange, Van Stone with lap flange or with weld or screw-fitting

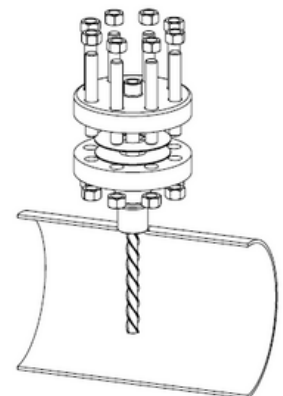

RF flange helical solid machined thermowell

PIPE MOUNTING TYPES

■ Welded flange thermowell

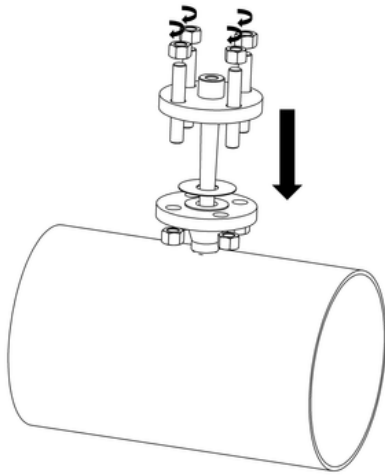

with RF flange

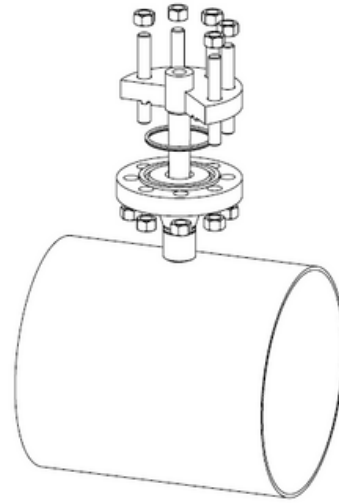

with RTJ flange

■ Van Stone thermowell

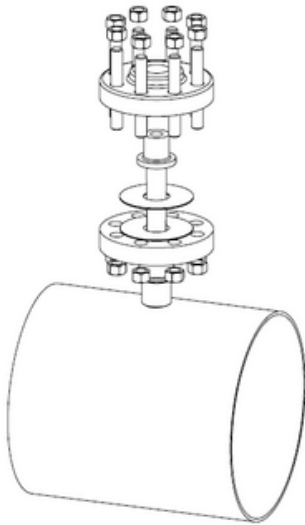

with RF flange

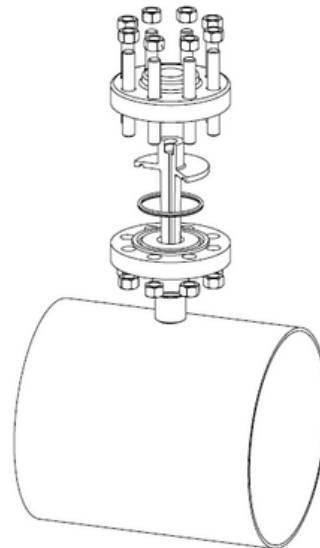

with RTJ flange

■ Screwed thermowell

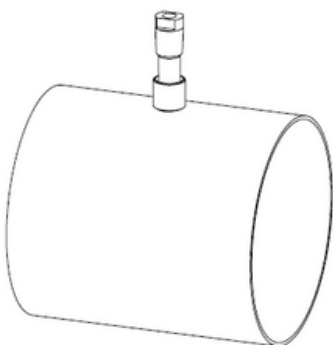

■ Welded thermowell

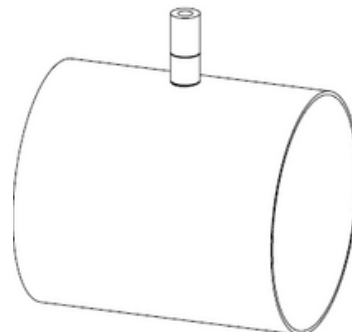

TEMPERATURE SENSOR & THERMOWELL CUSTOM ASSEMBLY

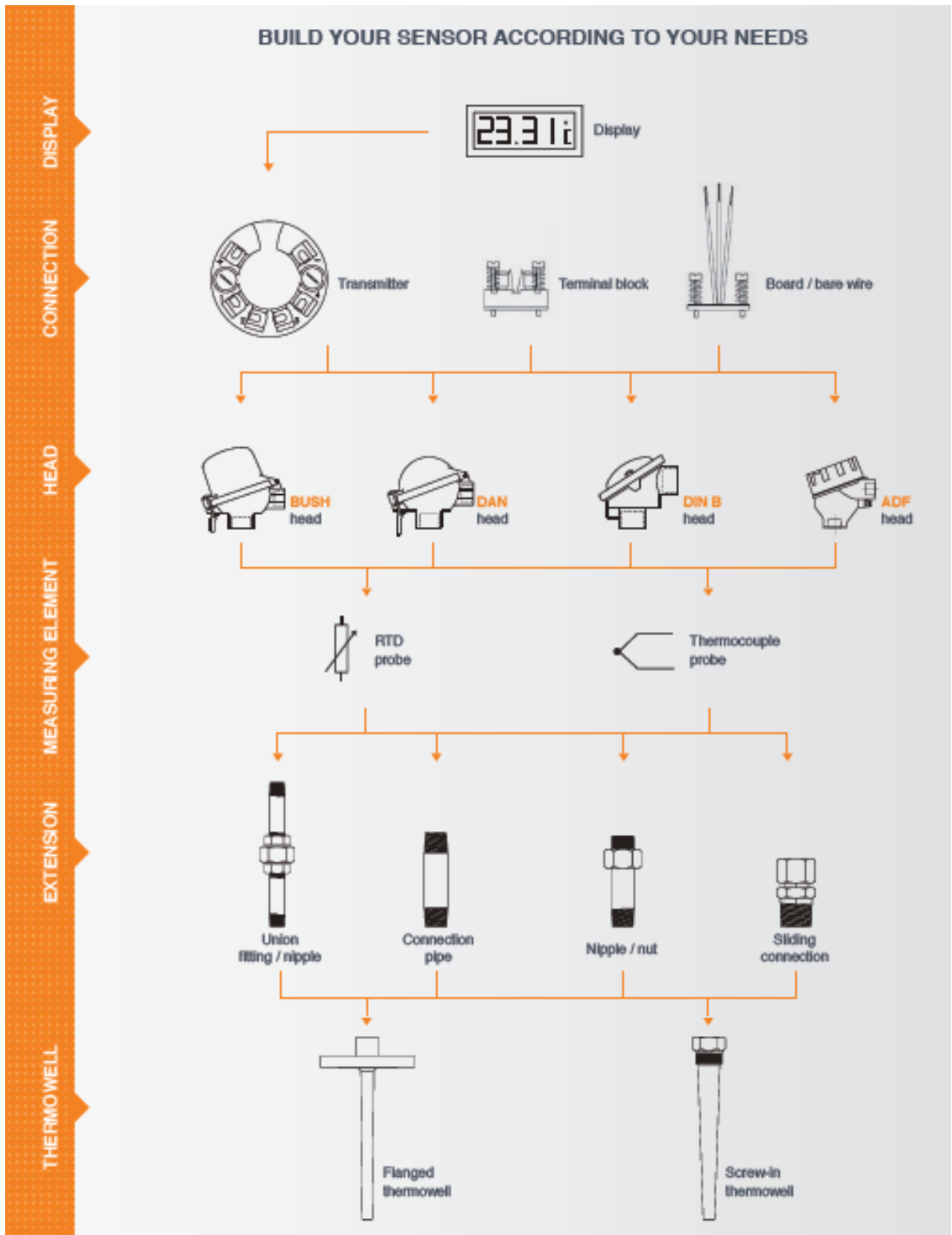

ACCESSORIES

For temperature measurement, we offer a complete range of accessories for assembling probes / heads / thermowells / extensions / fittings

Flanges



Flanges with flat gasket face, raised face, large male/female face, tongue/groove face, RTJ-F face

Temperature sensors



Pt100 RTD sensor or thermocouple

Heads



BUSH, DAN, DIN B, ADF heads

Fittings / nipples



FURTHER INFORMATION

All information on the mounting of thermowells with details on different types of assembly can be found on the IOM notice "User guide - Thermowell".



Chemin Les Augas – RD817
64170 LACQ
FRANCE



delta64@deltafluid.fr



+33 (0)5 59 30 85 20



www.deltafluid.fr



DELTAFLUID