

# TUBULAR THERMOWELL

For standard applications with no significant constraint

## GENERAL DATA<sup>(1)</sup>

- Material:
  - o Standard: SS 304L / 316L
  - o Others: according to your application
- All types of fluids in contact
- Coating possible for corrosive fluids

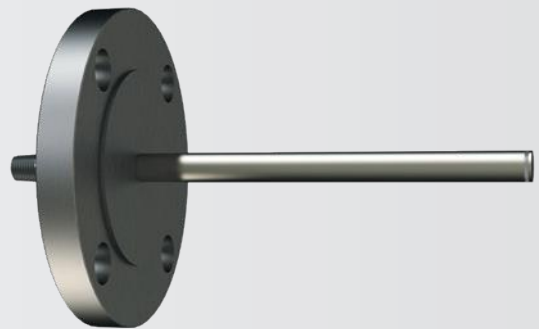
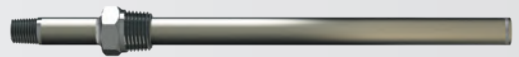
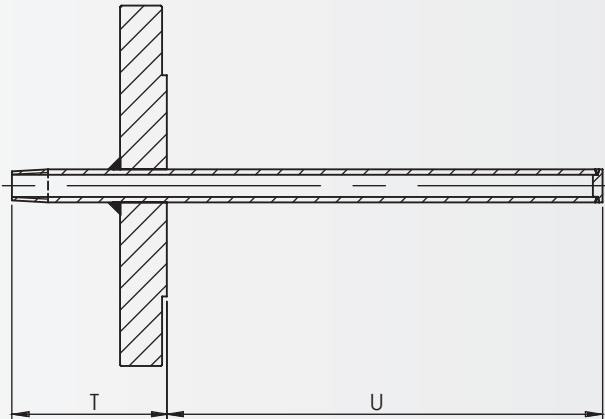
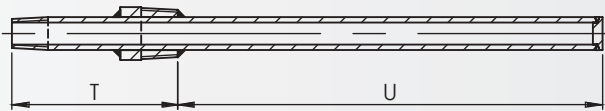
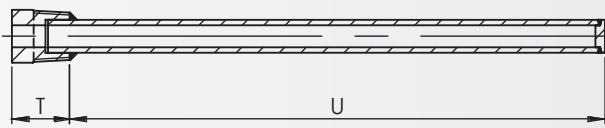

T, extension length  
U, insertion length under thread

## TECHNICAL CHARACTERISTICS<sup>(1)</sup>

Instrumentation connection	NPT thread or other on request
Process connection	Threaded, flanged, welded, clamp
Immersion length	According to customer specifications
Inside and outside diameter	According to the application
Maximum process pressure and temperature	According to the thermowell design (size, material, flange rating) and process conditions (flow rate, fluid velocity)

<sup>(1)</sup> Only standard data are exposed on this page. Other designs are available on request.